

HIDDEN TANK - INCITE 84" x 36" x 21"

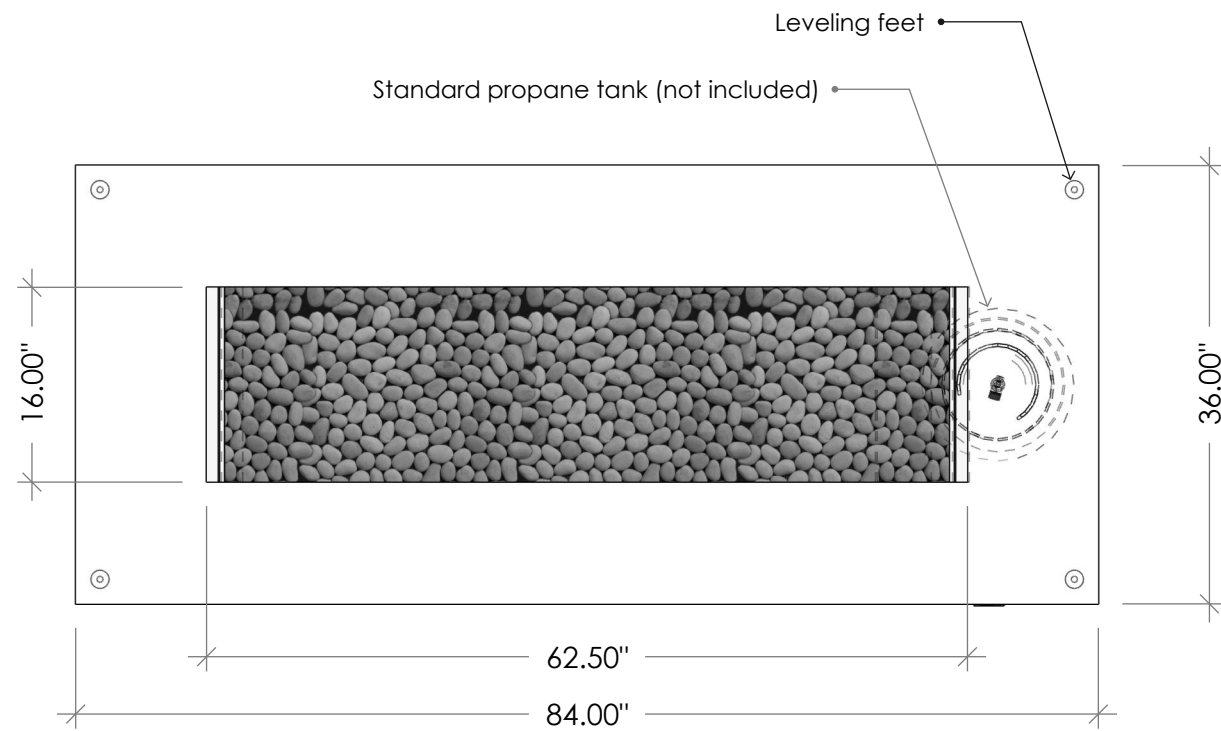

TOP VIEW

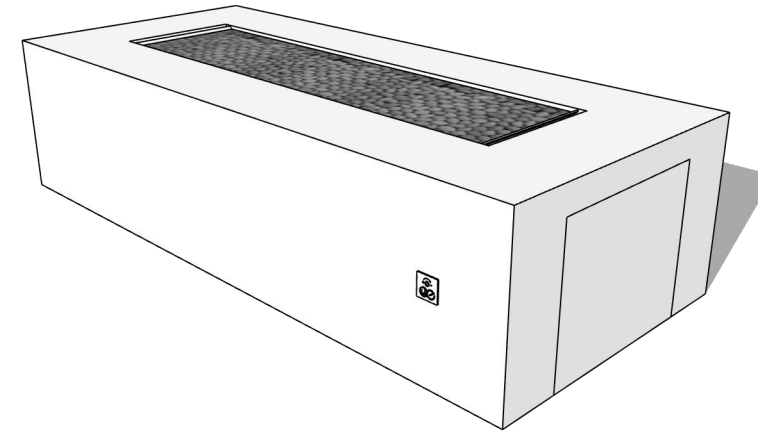

PERSPECTIVE VIEW

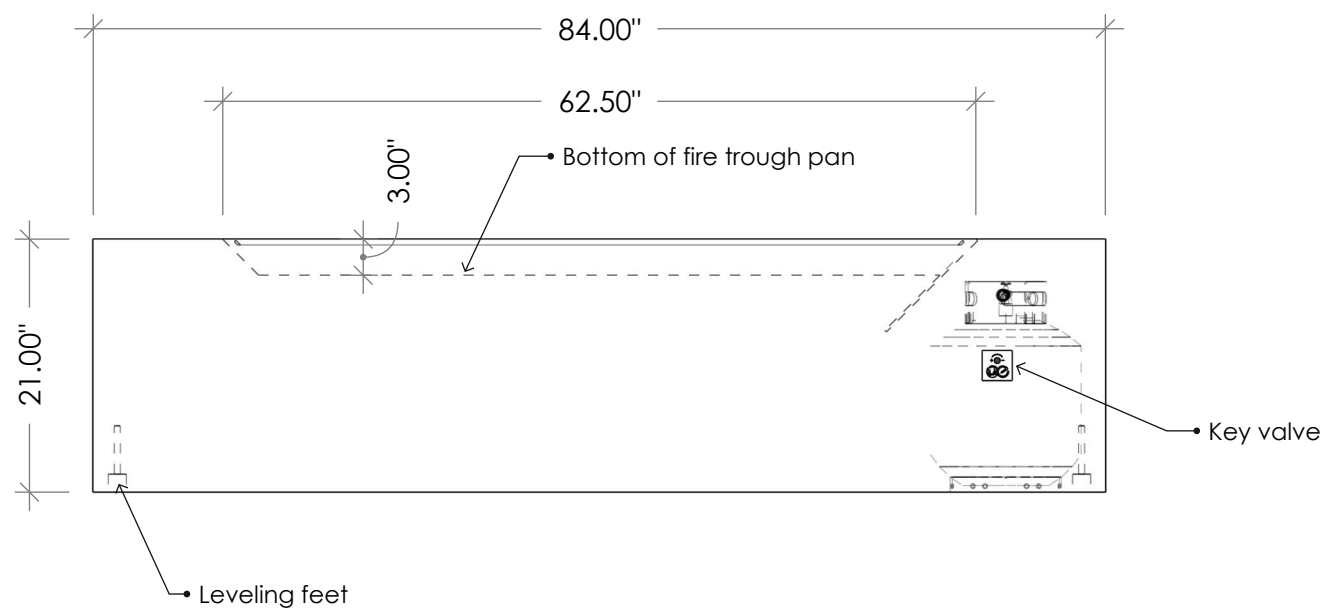

FRONT VIEW

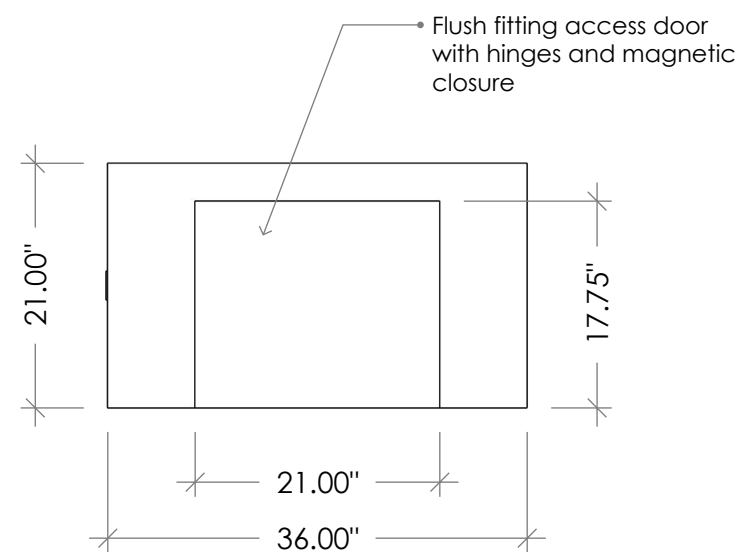

RIGHT SIDE VIEW

PLACEMENT REQUIREMENTS (to be completed before installation):

- Fire pit must be placed on solid (compacted) ground or finished hardscape (pavers, concrete, etc.).
- Please note that units made from rusted steel will likely stain adjacent hardscape surfaces.
- Please ensure that workers have good access to installation site (clear path from the street and entry through gates, etc.).

When the above preparations are completed, standard installations include the following:

- Delivery and placement of unit, including leveling
- Connection of fuel lines
- Testing for leaks and overall functionality
- Placement of fill material (lava or fire glass)
- User training, if desired

* Outdoor Elements guarantees the fire pit will arrive in perfect condition. We are not responsible for any damage occurring after delivery and/or installation. Treat the fire pit like fine furniture, do not allow other contractors to use it as a workbench, etc. If it is to be installed before other landscaping work is completed, we recommend covering and protecting the unit until all surrounding work is completed.

** If site is not ready as described above and a second trip is required, an additional fee may be applied.

SPECS & SITE PREP DETAILS

BTU RATING:
175,000 BTU

APPROX. WEIGHT (without fill):
Steel - 476 lbs
Aluminum - 194 lbs

RECOMMENDED FILL:
Tumbled lava - 173 lbs
Fire glass - 145 lbs

APPROX. BURN TIME AT FULL FLAME HEIGHT:
2.5 HRS

v1.0-2025

